

This is a NON RECOMMENDED LAYOUT. This layout will produce a very mild ball reaction and is not recommended.

**Drilling #5**

Ball Reaction: Very mild

Suitable for: Extremely high rev rates

Flare potential: Very Small

Pin Placement: Not recommended with this layout

Mass Bias Placement: Mass Bias Placements to the left of the thumb hole are not recommended because of the severe reduction in flare potential.

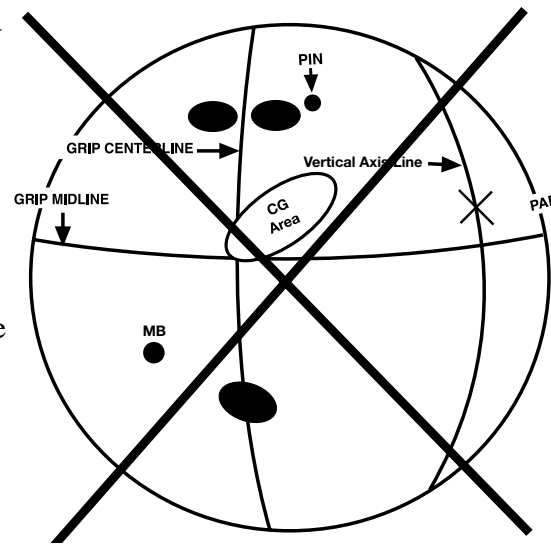

**Trick Tour Layouts**

**Tommy Jones Favorite Trick Layout**

Ball Reaction: Long and most aggressive at the breakpoint for Tommy Jones

Suitable for: High Rev Rates only

Flare potential: High

Pin Placement: Place Pin 1½ inches away from the Vertical Axis Line and 4½ inches away from the PAP

Center of Gravity: The center of gravity placement may or may not fall inside the CG area. If it doesn't then the balance hole location may need to be adjusted.

Mass Bias Placement: Mass Bias Placement at 80 degree angle to the right of the thumb hole. If needed place balance hole approx 4 inches to the right and drill the ball back to statically legal

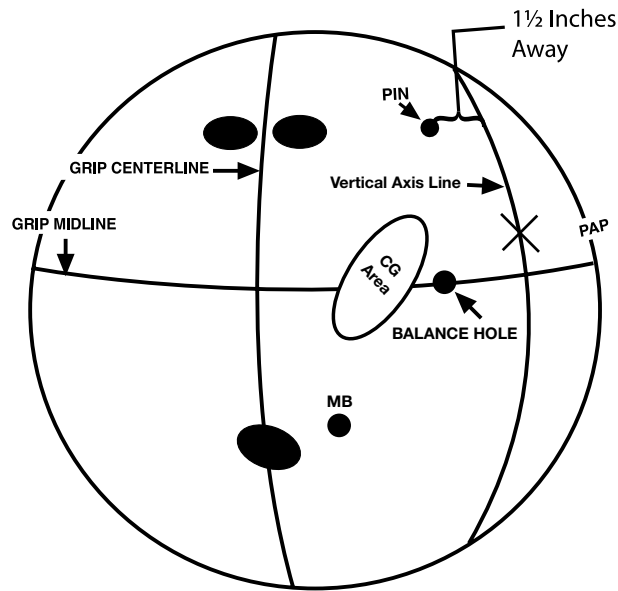

**Jason Couch Favorite Trick Layout**

Ball Reaction: Long and most continuous for Jason Couch

Suitable for: High Rev Rates only

Pin out distance must be at least 3.5 inches out.

Flare potential: High

Pin Placement: Place Pin: 1½ inches away from the Vertical Axis Line and 5¼ inches away from the PAP

Center of Gravity: The center of gravity placement may or may not fall inside the CG area. If it doesn't then the balance hole location may need to be adjusted.

Mass Bias Placement: Mass Bias Placement at 60 degree angle to the left of the thumb hole. If needed place balance hole approx 4 inches to the right and 1 inch up and drill the ball back to statically legal

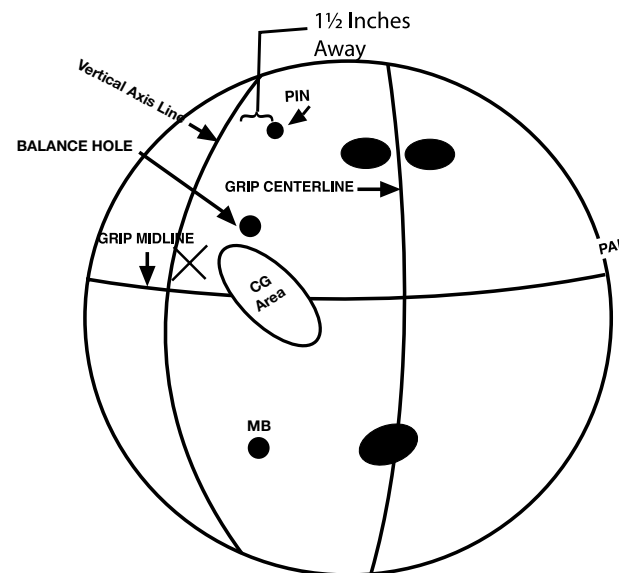

**MISSION**

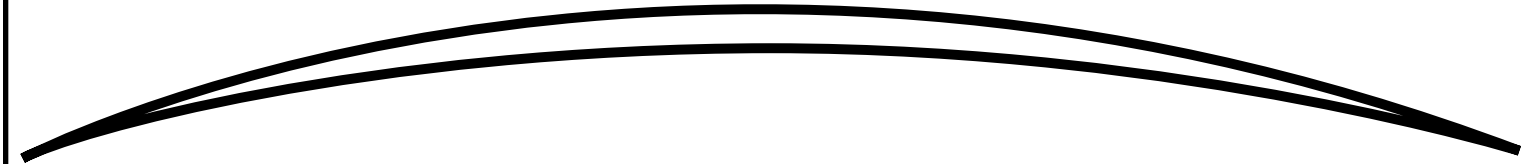

**Drilling Instructions**

<b>Core Design:</b>	<b>Mission 1.0</b>				
<b>Mass Bias Strength:</b>	<b>.013</b>				
<b>Mass Bias Location:</b>	<b>6 3/4" from the pin</b>				
<b>Coverstock Name:</b>	<b>XL1200</b>				
<b>Oil Absorption Rate:</b>	<b>10.1</b>				
<b>Color:</b>	<b>Red Pearl</b>				
<b>Box Finish:</b>	<b>500, 1000, 2000 Abralon Sanded</b>				
<b>Length: (Ebonite scale of 1 to 50, earliest to latest)</b>	<b>23</b>				
<b>Overall Hook: (Ebonite scale of 1 to 50, least to most)</b>	<b>47</b>				
<b>Breakpoint Angle (Ebonite scale of 1 to 15, most smooth to most angular)</b>	<b>14.50</b>				
<b>RG Values:</b>	<b>16</b>	<b>15</b>	<b>14</b>	<b>13</b>	<b>12</b>
	<b>2.48</b>	<b>2.48</b>	<b>2.59</b>	<b>2.59</b>	<b>2.62</b>
<b>Differential Values:</b>	<b>.049</b>	<b>.050</b>	<b>.052</b>	<b>.043</b>	<b>.046</b>



**Ebonite International**  
P.O. Box 746, Hopkinsville, KY 42241-0746  
270-881-1200 • 800-626-8350 • Fax 270-881-1201  
Visit our web site at [www.ebonite.com](http://www.ebonite.com)

# MISSION

## Mission Drilling Instructions

### **The Core:** Mission Symmetric Mass Bias Core 1.0

The Mission Symmetric Mass Bias Core, version 2.0 has been designed with a lower RG as well as lower differential while providing you with a strong mass bias strength. In our testing and evaluations we feel this combination provides a wider range of bowlers with the best overall performance.

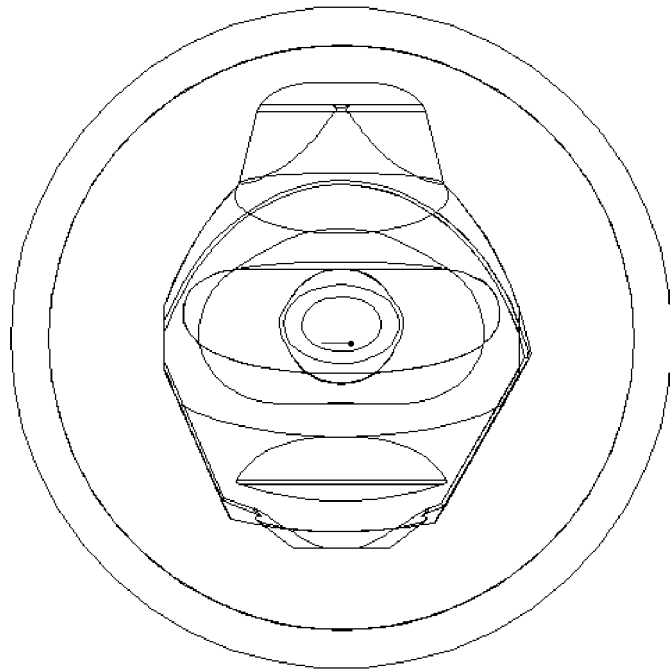

### **The Coverstock:**

In developing the XL generation of coverstocks, our team of chemists have focused on reducing oil absorption, while increasing the surface friction. This combination has allowed Ebonite to provide bowlers with products that provide strong back end continuation game after game. We know you are thoroughly going to enjoy your Mission, Game after Game!

### **Ball Care:**

Ball Care –Ebonite strongly suggests using Abralon Pads as well as Ebonite Powerhouse products. As far as cleaning, we recommend that you use Ebonite Powerhouse Energizer Ball Cleaner. As your ball starts to decrease in performance, you may need to refresh the cover with the Ebonite Hook Again System.

As your new Mission ball rolls down the lane, the surface will change. In order to keep your ball at peak performance, we suggest reviewing the [Ebonite Ball Maintenance Guide](#) for your Daily **Ball Maintenance requirements**.

This is the **recommended** layout for most players, with or without a positive axis point.

Use mirror image for left handed drilling.

### **Drilling #1**

If you do not have a positive axis point, use this layout.

Ball Reaction: Long and Strong

Suitable for: Most Styles and Lines

Flare potential: Medium

Center of Gravity: The center of gravity placement may or may not fall inside the CG Area. If it doesn't then the balance hole location may need to be adjusted.

Mass Bias Placement: Place Mass Bias 3 inches to the right of the thumb hole

If needed place balance hole 4 inches over and 1/2 inch up and drill back to statically legal.

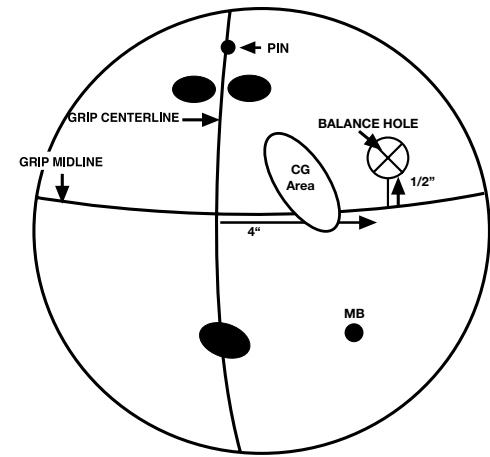

### **Drilling #2**

Ball Reaction: Long and Strong

Suitable for: Most Styles and Lines

Flare potential: Large

Pin Placement: Place Pin 4 1/2 inches from PAP

Center of Gravity: The center of gravity placement may or may not fall inside the CG Area. If it doesn't then the balance hole location may need to be adjusted.

Mass Bias Placement: Place Mass Bias at a 45 degree angle to the right of the thumb hole. If needed place balance hole over on the Vertical Axis Line and 2 inches down and drill back to negative side weight. The bigger and deeper the hole is the more increased ball reaction. Remember to keep the ball statically legal.

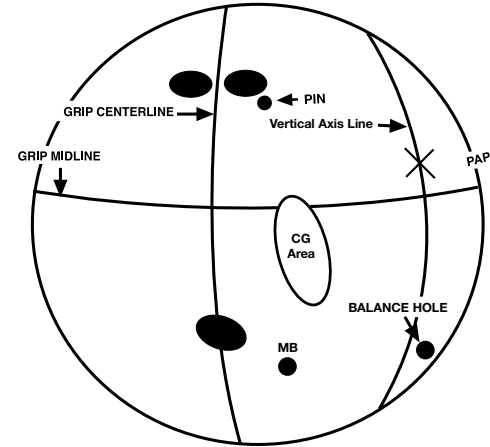

This layout produces the most even reaction with the highest TOTAL hook.

### **Drilling #3**

Ball Reaction: Early and Strong

Suitable for: High Ball Speed, Low RPM's, Heavy oiled lanes

Flare potential: Very Large

Pin Placement: Place Pin 3 1/2 inches from PAP

Center of Gravity: The center of gravity placement may or may not fall inside the CG Area. If it doesn't then the balance hole location may need to be adjusted.

Mass Bias Placement: Place Mass Bias in line with the Pin. If needed place balance hole over on the PAP and drill back to statically legal.

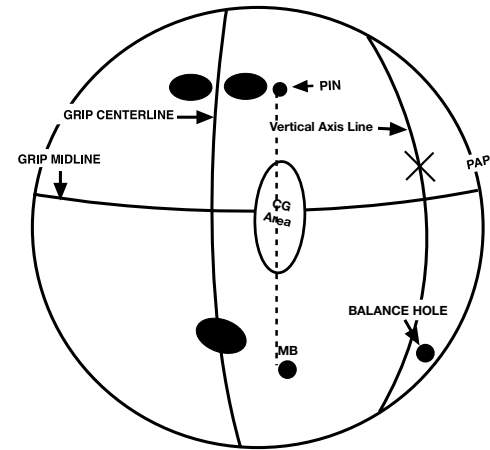

This is the recommended layout for All Full Rollers

### **Drilling #4**

Ball Reaction: Strong Arc

Suitable for: Most Styles and Lines

Flare potential: Large

Pin Placement: Place Pin 3 1/2 inches from bowlers center of span in an 8:00 direction.

Center of Gravity: The center of gravity placement may or may not fall inside the CG Area. If it doesn't then the balance hole location may need to be adjusted.

Mass Bias Placement: Place Mass Bias at a 2:00 direction from the center of span. If needed place balance hole 8 inches from the center of span in a 2:00 direction to remove excess positive side weight. Place balance hole 6 inches from the center of span in a 8:00 direction to remove excess negative side weight.

